



PARKS & RECREATION BOARD MEETING
THURSDAY, MARCH 19, 2026 at 7:00 PM
COUNCIL CHAMBERS
18500 W. 13 MILE ROAD
BEVERLY HILLS, MI 48025

AGENDA

- 1. Call to Order**
- 2. Amendments to the Agenda/Approve Agenda**
- 3. Public Comments**
- 4. Approve minutes of a Parks & Recreation Board meeting held February 19, 2026**
 - A. Approve Parks & Recreation Board Minutes from February 19, 2026
- 5. Business Agenda**
 - A. Review & consider request to waive the pavilion rental fee for Beverly Elementary back-to-school event
 - B. Review & consider request to waive the pavilion rental fee for Birmingham Public Schools Professional Development Day
 - C. Review and consider artists for Concert in the Park Series
 - D. Review and consider 2026 Sculptures in the Parks recommendations.
 - E. Review and consider Riverside Park Improvement Project bids
- 6. Discussion**
 - A. Memorial Day
 - B. Park Clean Up
- 7. Public Comments**
- 8. Administration Comments**
- 9. Liaison Comments**
- 10. Board Comments**

11. **Adjournment**

Persons with disabilities who need assistance to participate in this meeting should contact the Clerk's office at 248-646-6404 three days in advance to request mobility, visual, hearing other assistance.

DRAFT REGULAR PARKS & RECREATION BOARD MEETING MINUTES – FEBRUARY 19, 2026– PAGE 1

Present: Chairperson Goodrich; Vice Chairperson Ross; Members Bayless, Kreit, O’Gorman and Ruprich

Absent: Secretary Bresnahan; Borgon, Hausman and O’Gorman

Also Present: Public Service Director, Johnston
Council Liaison, Hrydziuszeko

Chairperson Goodrich called the regular Parks & Recreation meeting to order at 7:00 p.m. at the Beverly Hill Village Council Chambers located at 18500 W. 13 Mile Road, Beverly Hills, MI 48025.

APPROVE AGENDA

Motion Bayless, second by Kreit, to approve the agenda as published.

Motion passed.

REVIEW AND CONSIDER APPROVAL OF JOINT VILLAGE COUNCIL/ PARKS & RECREATION BOARD MINUTES OF MEETING HELD JANUARY 15, 2026

Motion by Ross, second by Kreit, to approve the minutes of the joint Village Council/ Parks & Recreation Board meeting held January 15, 2026 as submitted.

Motion passed.

PUBLIC COMMENTS

Mike White inquired about getting a memorial bench for Jim Nawara.

REVIEW AND CONSIDER REQUEST TO WAIVE PAVILION RENTAL FEE FOR THE ANNUAL 6TH SCHOOLS OFFER SUPPORT (SOS) 5K

Motion by Bayless, second by Ross, the Beverly Hills Parks & Recreation Board recommends that Village Council approve the request from Schools Offer Support to hold a 5K Run/1 Mile race on Sunday, September 27, 2026 from 7:00 a.m. to 11:00 a.m. This event will begin and end at the Beverly Park pavilion and they will utilize Village streets and sidewalks for the run. It is recommended that fees for use of the pavilion be waived for this event provided that a \$250 refundable damage deposit and Certificate of Liability Insurance naming the Village of Beverly Hills as an additional insured is submitted to the Clerk’s Office prior to the event.

Motion passed.

REVIEW AND CONSIDER REQUEST TO WAIVE PAVILION RENTAL FEE FOR THE ANNUAL ITP-PUMP IT UP FOR PLATLET WALK

Motion by Bayless, second by Kreit, the Parks and Recreation Board recommends that the Village Council approve the request from the Platelet Disorder Support Association to hold

the ITP 5K at Beverly Park on Saturday, October 3, 2026 from 10:30 a.m. to 1:30 p.m. and waive the pavilion rental fees during that time provided that a \$250 refundable damage deposit and Certificate of Liability Insurance naming the Village of Beverly Hills as an additional insured is submitted to the Clerk’s office prior to the event.

Motion passed.

REVIEW AND CONSIDER REQUEST TO WAIVE PAVILION RENTAL FEE FOR THE BERKSHIRE PROUD DAD CLUB’S CHILI COOK-OFF

Motion by Bayless, second by Kreit, the Beverly Hills Parks & Recreation Board recommends that Village Council approves the request from Berkshire Proud Dads Club to hold a Chili Cook-Off on Saturday, April 25, 2026 from 2:00 p.m. to 6:00 p.m. It is recommended that fees for use of the pavilion be waived for this event provided that a \$250 refundable damage deposit, and a Certificate of Liability Insurance naming the Village of Beverly Hills as an additional insured is submitted to the Clerk’s Office prior to the event. Furthermore, it is also recommended that Council waive the sales restrictions (Municipal Code Section 28-22 Amusement for Gain) for this event.

Motion passed.

REVIEW AND CONSIDER REQUEST TO WAIVE PAVILION RENTAL FEE FOR THE BEVERLY HILLS LITTLE LEAGUE OPENING DAY CELEBRATION

Motion by Bayless, second by Kreit, the Beverly Hills Parks & Recreation Board recommends that Village Council approve the request from the Beverly Hills Little League to host the BHLL Opening Day celebration at Beverly Park on Saturday, May 2, 2026 from 12:30 p.m. to 3:30 p.m. It is recommended that fees for use of the pavilion be waived for this event provided that a \$250.00 returnable damage deposit and a Certificate of Liability Insurance naming the Village of Beverly Hills as an additional insured is submitted to the Clerk’s Office prior to the event.

Motion passed.

REVIEW AND CONSIDER THE SMITHGROUP’S WENDBROOK MASTER PLAN PROPOSAL

Ross stated that during the joint meeting with Council it was agreed that a professional planning consultant should assist with development of the Wendbrook property and the Village worked with The SmithGroup on the Beverly Park Plan with positive results.

Motion by Ross, second by Ruprich, the Parks and Recreation Board accepts the proposal from the SmithGroup and recommends the Village Council approves the proposal from the SmithGroup for development of a plan for the Wendbrook property.

Motion passed.

APPROVE RYAN BILLS TRIO AS ARTIST FOR JAVA & JAZZ SERIES

Motion by Bayless, second by Ruprich, the Parks and Recreation Board approve the Ryan Bills Trio to perform at the five 2026 Java and Jazz concerts, to be held every third Sunday from May through September, from 9:00 a.m. to 12:00 noon at the Beverly Park Pavilion, at a rate of \$1,000 per concert, for a total cost of \$5,000, with funding allocated in accordance with the Village Council’s October 21 authorization and the adopted Village budget.

Motion passed.

ASSIGN A COMMUNICATIONS CHAIR

Goodrich opened the floor for nominations for Communications Chair Kreit, with support from Ruprich, nominated Bayless. There were no other nominations.

Bayless was elected to serve as Communications Chair unanimously.

DISCUSSION TOPICS

A. CONCERTS IN THE PARK

The Board discussed potential artists for the Concerts in the Park, staging and trying dessert trucks instead of a full food truck for some events. Brown will bring a full list of band options for the Board at the next meeting, and the Board will review promotional material before final selection.

B. MEMORIAL DAY PARADE/CARNIVAL/CEREMONY

Goodrich shared updates received from Hausman via email regarding Memorial Day including RAPP grant approval for mobile units, parade participation and sponsorship letters. The Board discussed encouraging parade participants to keep the focus on the holiday’s meaning, adding special recognition to the event like a military flyover or additional flags and the sound system during the ceremony.

Goodrich informed the Board that the Village received a \$250,000 grant from Congresswoman Tlaib.

PUBLIC COMMENTS

Stephanie Jones, Beverly Road, expressed support for adding public memorial features in the park and requested consideration of a memorial for a longtime resident that contributed to landscape and design work in the community. Jones also suggested that the fly traps at Beverly Park be updated and sponsorship letters be sent out earlier.

ADMINISTRATION COMMENTS

Johnston provided additional information on the grant received from Congresswoman Tlaib’s office for Beverly Green improvements. Johnston informed the Board that the Beverly Park playscape project is being finalized for bid pending Michigan DNR approval and Riverside Phase

2 is currently out to bid. The Board selected dark green as the color of the benches and trash receptacles for Riverside. Johnston provided updates on future projects which included the Beverly Park fence replacement, Wendbrook concept design, Eryty Dam Feasibility Study and ongoing maintenance and seasonal park work.

LIAISON COMMENTS

Hrydziuszko reported attending a recent meeting regarding the Eryty Dam Feasibility Study. Hrydziuszko stated that the study will not make recommendations but will provide data for Council to consider, including impacts of repair, removal or replacement as well as dredging requirements, environmental conditions and potential costs to homeowners.

BOARD COMMENTS

Kreit informed Johnston and the Board about the damaged gate at Beverly Park and the down sign at Pierce.

Ross submitted a tree grant application to the Arbor Day Foundation.

Goodrich read comments received from Hausman stating that the portals will remain installed longer, possibly until warmer temperatures, the Lions Club will sponsor the refreshments for Java and Jazz and a sponsorship letter was sent out to Jim Shaffer and Associates regarding sponsoring the Concerts in the Park again. Goodrich also read Hausman's report that stated that 24 Sculptures in the Park submissions were received and recommendations will be presented at the next meeting. Goodrich stated that the holiday lights at the park will be coming down next month.

ADJOURNMENT

The meeting was adjourned at 8:09 p.m.



Agenda Item Summary

To: Parks & Recreation Board
From: Carissa Brown, Village Clerk

Re: ***Business Agenda - A. Review & consider request to waive the pavilion rental fee for Beverly Elementary back-to-school event***

Date: March 19, 2026 - [Click to View Agenda](#)

Summary:

Administration has received a request from Beverly Elementary to host a back-to-school event for families in the community on Friday, September 11, 2026 from 4:00 p.m. to 8:00 p.m. The event is intended to support students and families as they prepare for the upcoming school year. It would provide an opportunity for families to connect with one another and access helpful back-to-school information and resources. There are no conflicting events scheduled at Beverly Park during this time.

Recommendation:

The Beverly Hills Parks & Recreation Board recommends that Village Council approve the request from Beverly Elementary to host a back to school event on Friday, September 11, 2026 from 4:00 p.m. to 8:00 p.m. . It is recommended that fees for use of the pavilion be waived for this event provided that a \$250 refundable damage deposit and Certificate of Liability Insurance naming the Village of Beverly Hills as an additional insured is submitted to the Clerk's Office prior to the event.

Attachments:

1. Pavilion Waiver Form Beverly Elementary Back to School



Beverly Park Pavilion Rental Fee
Waiver Request Form

Organization Beverly Elem. Contact Name Linda Johnson

Address 18305 Beverly Rd.

City, State, Zip Beverly Hills MI 48025

Phone Number [Redacted] Email Address [Redacted]

Select one:

Non-Profit Public School Other _____

Tax ID Number 38-6003045

Date of Event 9/11/26

Time of event 4:00 a.m./p.m. to 8:00 a.m./p.m.

Reservations are accepted between April 1 and November 30 between the hours of 9:00 a.m. and 9:00 p.m. Please note, reservations cannot be made on major holidays such as Memorial Day, Mother's Day, Father's Day, Independence Day, Labor Day, or during Village sponsored events such as the Halloween Hoot. \$250.00 damage deposit required.

Number of attendees 150 (maximum 150)

Tell us about your event and how it benefits the community:

This is a back to school event for families in the Beverly Hills Community who attend Beverly Elementary.

Is your event open to the public? Yes No

Please attach any supporting documents, such as a 5K route.



Agenda Item Summary

To: Parks & Recreation Board
From: Carissa Brown, Village Clerk

Re: ***Business Agenda - B. Review & consider request to waive the pavilion rental fee for Birmingham Public Schools Professional Development Day***

Date: March 19, 2026 - [Click to View Agenda](#)

Summary:

Administration has received a request from the Birmingham Public Schools to host a Professional Development/Employee Appreciation Day on Friday, July 10, 2025 from 7:00 a.m. to 3:30 p.m. The event is proposed to take place at the Beverly Park Pavilion and at Beverly Elementary School. Planned activities include workshops, games, and other staff engagement activities. There are no conflicting events scheduled at Beverly Park during this time.

Recommendation:

The Beverly Hills Parks & Recreation Board recommends that Village Council approve the request from Birmingham Public Schools to host a professional development/ employee appreciation event on Friday, July 10, 2026 from 7:00 a.m. to 3:30 p.m. It is recommended that fees for use of the pavilion be waived for this event provided that a \$250 refundable damage deposit and Certificate of Liability Insurance naming the Village of Beverly Hills as an additional insured is submitted to the Clerk's Office prior to the event.

Attachments:

1. Pavilion Waiver Form BPS Professional Development Day



Beverly Park Pavilion Rental Fee Waiver Request Form

Organization Brim Public Schools Contact Name Heather Guise

Address 2305 Cole Street

City, State, Zip Brim, MI 48009

Phone Number [redacted] Email Address [redacted]

Select one:

Non-Profit Public School Other _____

Tax ID Number 38600345

Date of Event Friday July 10

Time of event [redacted] *Prefer 7-3:30 if possible*

Reservations are accepted between April 1 and November 30 between the hours of 9:00 a.m. and 9:00 p.m. Please note, reservations cannot be made on major holidays such as Memorial Day, Mother's Day, Father's Day, Independence Day, Labor Day, or during Village sponsored events such as the Halloween Hoot. \$250.00 damage deposit required.

Number of attendees 100 (maximum 150)

Tell us about your event and how it benefits the community:

This is a Professional Development event for the Operations Dept. We will be going between Beverly School + the park for workshops, games, etc. *Employee appreciation*

Is your event open to the public? Yes No

Please attach any supporting documents, such as a 5K route.

Pavilion rental fees are charged to cover the Village’s costs to set up and maintain the Pavilion for public use. Submittal of this form does not guarantee the rental fees will be waived. Waiver of fees is considered in support of charitable and other activities that broadly benefit residents of the Village. Requested dates and times are subject to availability. Fees waivers are granted only once per year for a given organization. All requests are subject to Village Council approval. Procedurally, the Parks & Recreation Board will review the request and then offer a recommendation to Council.

Please send requests to the Village Clerk by the deadline below.

Email: cbrown@villagebeverlyhills.com

Mail: Village of Beverly Hills
 Attn: Village Clerk
 18500 W. 13 Mile Road
 Beverly Hills, MI 48025

2026 Deadlines

Deadline to Submit Admin	Parks & Rec Meeting Recommendation	Village Council Meeting Final Approval
February 9, 2026 March 9, 2026	February 19, 2026 March 19, 2026	March 3, 2026 April 7, 2026
April 6, 2026 May 11, 2026	April 16, 2026 May 21, 2026	April 24, 2026 June 2, 2026
June 8, 2026 July 6, 2026	June 18, 2026 July 16, 2026	July 7, 2026 July 21, 2026
August 10, 2026 September 7, 2026	August 20, 2026 September 17, 2026	September 1, 2026 October 6, 2026
October 5, 2026 November 9, 2026	October 15, 2026 November 19, 2026	October 20, 2026 December 1, 2026



Agenda Item Summary

To: Parks & Recreation Board
From: Carissa Brown, Village Clerk

Re: *Business Agenda - C. Review and consider artists for Concert in the Park Series*
Date: March 19, 2026 - [Click to View Agenda](#)

Summary:

The Village will host three Concerts in the Park this summer on June 5, July 17, and August 14. Several artists and bands have reached out to the Village expressing interest in performing, and staff has also contacted performers from last year's concert series. An attachment is included listing the artists along with a brief background, availability, and performance rates. This information is being provided for review and consideration.

Financial Impact:

Last year, Council approved continuing the Concert in the Park series for the upcoming season with a budget not to exceed \$4,500 to cover artist fees and stage rentals.

Recommendation:

The Beverly Hills Parks & Recreation Board approves the following Concert in the Park artists for 2026:

_____ for the June 5th concert, _____ for the July 17th concert and _____ for the August 14th concert.

Attachments:

1. Concert in the Parks Series 2026

Concert in the Parks Series 2026

Artist/Band	Harmonized Steel
Background	<p><i>Harmonized Steel is a 5 piece Classic Rock band, based in the Howell/Hartland area. The band consists of two guitar players, a keyboard player, bass player, and drummer. Our keyboard player, drummer, and one of the guitar players do lead vocals. Everyone sings background vocals.</i></p> <p><i>The band has been together for a number of years. We have played many places including Walled Lake, South Lyon, Fowlerville, Wings Etc in Hartland, The Rec Bowl in Mt. Clemens, numerous parties, Lehlalooza in Topinabee Michigan, and Northland s Brewing in Indian River Michigan for the Top of Michigan Boat Races.</i></p>
Available Dates	June 5 th
Performance Rate	\$500.00
Link to Promotional Material	https://www.facebook.com/groups/harmonizedsteel

Artist/Band	Weekend ComeBack
Background	<p><i>With a four-piece ensemble, Weekend ComeBack is the perfect band to get your party started. Depending on the season, we play 3-5 gigs per week in and around Metro-Detroit. Our music spans decades, ranging from the 60s to the hottest hits of today. We pride ourselves on our ability to keep the crowd engaged and entertained, playing songs that will have everyone singing and dancing along. We are a variety-band so our song-list includes most genres, (pop, rock, country).</i></p>
Available Dates	July 17 th
Performance Rate	\$1000.00
Link to Promotional Material	<ul style="list-style-type: none"> • https://link.edgepilot.com/s/7479fc23/6zTpksxDeUKagbPorLOcAw?u=https://youtu.be/u6MQnB2oL74?si=Nv5yziydelQ5-hZO • https://link.edgepilot.com/s/29e0e1f5/DA4PhXOQd0m2_abcGt67vw?u=https://youtu.be/FS8snnnezBoo?si=ZEMOYzMbjGHw85SL • https://link.edgepilot.com/s/63a45930/hMx3jOs8jkCMmKsdERT39Q?u=https://www.youtube.com/watch?v=lv4gbfuUFwc

Concert in the Parks Series 2026

Artist/Band Royal Oak Blue Band
<p>Background <i>Founded in 2018, we are a four-piece band featuring three vocalists, harmonica, electric guitar, octave mandolin, bass and drums. We perform classic cool blues tunes at a reasonable sound level.</i></p> <p><i>Members of the band are all veteran performers and the group is friendly, reliable, and professional.</i></p>
Available Dates June 5 th and July 17 th
Performance Rate \$500
<p>Link to Promotional Material</p> <ul style="list-style-type: none"> • https://www.facebook.com/RoyalOakBluesBand • https://link.edgepilot.com/s/03d3fb42/zqCQTUJ9zkC5uu95ccNRqA?u=https://www.youtube.com/@royaloakbluesband8778

Artist/Band Cliff Erickson
<p>Background <i>Cliff Erickson is considered one of the finest acoustic performers throughout the Midwest and southwestern Ontario. His musical instincts are clearly portrayed in his original work along with his amazing ability to capture the passion evoked by countless cover tunes. His soothing voice and his extraordinary talent on his signature 12-string acoustic guitar captivate his listeners as he takes them along on what has been best described as an “unparalleled musical excursion.”</i></p>
Available Dates July 17 th (would like to perform in the pavilion again; no stage)
Performance Rate \$1200
Link to Promotional Material https://clifferickson.com/videos

Artist/Band Bernadette Kathryn and the Lonely Days Band
<p>Background <i>From the city that keeps America driving, Bernadette Kathryn is a fresh and exciting addition to Detroit’s storied history of musical talent. While Bernadette is immersed in the world of contemporary young country, she draws on the Motor City’s long tradition of great music, from Motown to rock & roll. In a cookie-cutter world of sound-alike singers, Bernadette Kathryn is truly Detroit’s Country Rebel.</i></p> <p><i>Bernadette Kathryn is proud to be a Nashville recording artist, and is marketed and distributed internationally by The Orchard.</i></p>
Available Dates July 17 th
Performance Rate \$1600 (Meal must be provided for the band)
Link to Promotional Material https://www.facebook.com/BernadetteKathryn1



Agenda Item Summary

To: Parks & Recreation Board
From: Carissa Brown, Village Clerk
Janice Hausman, Parks & Recreation Board Member

Re: ***Business Agenda - D. Review and consider 2026 Sculptures in the Parks recommendations.***

Date: March 19, 2026 - [Click to View Agenda](#)

Summary:

2026 marks the 5th year of the Village of Beverly Hills' *Sculptures in the Parks Program*. The program continues to enhance the community by integrating public art within the Village's natural park settings.

A call to artists was issued by the Parks & Recreation Board inviting sculpture artists to submit applications featuring original works of a size, weight, and material suitable for outdoor display. Selected sculptures are intended to demonstrate the connection between art and the natural environment. The deadline for artist submissions was February 15, 2026.

A three-member jury reviewed all artist submissions and provided the Parks & Recreation Board with recommendations for sculpture selections. Secretary Bresnahan and Board Member O'Gorman will present the jury's recommendation.

Chosen sculptures will be on loan from the artist to the Village for a three-year exhibition period, from May 2026 through April 2029.

Financial Impact:

A \$1,200 stipend will be paid to each selected artist upon installation of their sculpture.

Recommendation:

Be it resolved, the Parks & Recreation Board accepts the jury's recommendations for the 2026 Sculptures in the Parks Program and approve the installation of the following sculptures:

_____, _____, _____, _____, and _____ for the three-year loan period of May 2026 through April 2029, with a \$1,200 stipend paid to each participating artist upon installation.

Attachments:

None



Agenda Item Summary

To: Parks & Recreation Board
From: Neil Johnston, Public Services Director

Re: ***Business Agenda - E. Review and consider Riverside Park Improvement Project bids***

Date: March 19, 2026 - [Click to View Agenda](#)

Summary:

A Request for Proposal was published on February 10, 2026, for the Riverside Park Improvement Project. Ten bids were received on March 11, 2026. The lowest qualified bid was submitted by Rolar Construction Corp of Warren, MI for \$119,784.00.

This project consists of:

- Installing material to grade the area.
- Installing a 5-foot crushed stone pathway that extends from the sidewalk on Riverside Dr. and loops around the peninsula.
- Planting native perennials species inside of the loop and grass seed outside.
- Installing 30-inch solar powered bollard lights around the pathway.
- Pouring four concrete pads and installing a green bench and trash can at each.
- Installing a kayak launch with a large boulder boarder.

Funds for this project are available through the Parks and Recreation Millage Fund.

The RFP, bid tabulation, map, and product specs are attached.

Village Administration is requesting that the Parks and Recreation Board recommend the following resolution to Village Council.

Financial Impact:

While the bid amount is \$119,784.00, staff is requesting **authorization not to exceed \$132,000.00**. The additional amount is requested to provide contingency funds in the event of

unforeseen conditions, minor change orders, or other project-related adjustments that may arise during construction.

Recommendation:

Be it resolved, the Parks & Recreation Board recommends Beverly Hills Village Council approves the proposal from Rolar Construction Corp. to perform improvements to Riverside Park in an amount not to exceed \$132,000.00. Funds are available in 208-900-974.10.

Attachments:

- 1. RFP Riverside Park Improvements Project Plans 02102026
- 2. Bid Tab Riverside Park Improvement Project 3112026
- 3. Rolar_Riverside_Park_20260313



**REQUEST FOR PROPOSAL
VILLAGE OF BEVERLY HILLS
RIVERSIDE PARK LANDSCAPE IMPROVEMENT PROJECT**

The Village of Beverly Hills is seeking competitive bids to complete a landscape improvement project at Riverside Park. The project consists of adding and grading soils, installing a stone pathway, solar bollard lighting, a boulder bordered kayak launch, concrete pads with benches and trash receptacles, and the planting of perennial wildflowers, ornamental grasses, trees and grass seed. It is highly recommended site visits are made before bid submittal.

Riverside Park is located on the south side of Riverside Drive, 500 feet east of Evergreen Road.

Sealed bids for the Riverside Park Landscape Improvement Project will be received until **11:00 AM on Wednesday, March 11, 2026**, by the Village Clerk's Office located at 18500 West 13 Mile Road, Beverly Hills, MI 48025, where they will be publicly opened.

Any questions or site visit requests should be submitted to Neil Johnston, via email njohnston@beverlyhillsmi.gov or by phone at 248-646-6404, **by Wednesday, March 4, 2026**, so they can be properly addressed before the submittal deadline.

The Village of Beverly Hills reserves the right to reject any or all bids or portions thereof for any reason. No bid may be withdrawn for at least 30 days after scheduled closing time for receipt of bids. The cost of preparing and submitting a proposal is the responsibility of the firm and shall not be chargeable in any manner to the Village.

Published on MITN: February 10, 2026



GENERAL SPECIFICATIONS

Riverside Park Improvement Project Village of Beverly Hills, Michigan

1. GENERAL DESCRIPTION

This project consists of park improvements at Riverside Park, including earthwork, grading, pathway construction, concrete pads, site furnishings, solar lighting, a kayak launch area with boulder edging, native plantings, stone mulch installation, and turf restoration. The Contractor shall provide all labor, equipment, materials, permits, and incidentals necessary to complete the work as specified.

2. PROJECT LOCATION

Riverside Park is located on the south side of Riverside Drive, 500 feet east of Evergreen Road



3. SCOPE OF WORK

3.1 Earthwork & Grading

- Perform clearing, grubbing, and removal of debris as needed.

- Excavate and grade to establish proper elevations for pathways, concrete pads, planting beds, and kayak launch area.
- Ensure positive drainage away from structures, pathways, and activity areas.
- Import or export soil as necessary to meet design grades.
- All earthwork shall conform to MDOT standards for compaction and surface preparation.

3.2 DG Pathway Construction

Construct a 550-foot-long, 5-foot-wide Decomposed Granite (DG) looped pathway, consisting of:

Base Preparation

- Excavate to accommodate the full section depth.
- Install 4 inches of compacted 21AA crushed limestone base, graded and compacted to MDOT standards.

Surface Material

- Install 3 inches of Decomposed Granite, raked smooth, and compacted to a firm, stable walking surface.
- Finished pathway shall be uniform in width, thickness, and grade, with smooth transitions at terminations and intersections.
- Finished DG surface shall be firm, stable, and resistant to rutting, displacement, and ponding under normal pedestrian use and typical seasonal weather conditions.

Edges

- Provide clean, compacted edges; ensure DG does not spill into adjacent turf or planting areas.

3.3 Concrete Pads and Site Furnishings

Install four (4) concrete pads, each measuring 5 ft × 10 ft × 6 in, placed along the shoreline of the peninsula.

Concrete Pads

- 6-inch-thick concrete (3,500 psi minimum).
- 4-inch compacted 21AA crushed limestone aggregate subbase.
- Broom finish, edges tooled.
- Pads shall slope slightly for drainage.

Site Furnishings

- Install benches and trash receptacles on each pad (exact models provided by the Village or per approved submittals).
- Anchor furnishings to pads using manufacturer-recommended hardware.
- Ensure alignment with shoreline and consistent placement across all pads.

3.4 Solar Light Bollards

Install nineteen (19) solar-powered light bollards along the DG pathway.

- Bollards shall be durable, vandal-resistant, and rated for outdoor park use (exact models provided by the Village or per approved submittals).
- Space bollards at consistent intervals unless site conditions dictate adjustment.
- Install per manufacturer requirements, including recommended footing or anchoring method.
- Bollards shall be surrounded by half-circle shaped bed with an 18-inch radius that includes two (2) ornamental grasses and one (1) perennial plant.
- Verify all solar units function before final acceptance.

3.5 Kayak Launch Area

Construct a kayak launch zone with naturalistic edging.

Launch Installation

- Excavate, grade, and compact the area to create a stable launch location.
- Install firm, stable grass surface suitable for foot traffic and kayak entry.

Boulder Border

- Install nine (9) boulders, each 3 to 4 feet in size, arranged to define and protect the launch perimeter.
- Boulders shall be partially buried (minimum 1/4 depth) for stability.

3.6 Landscaping and Planting

Native Perennial Planting

- Install 250 native perennial plants and 50 ornamental grasses, sized 1–3 gallon, arranged per landscape plan or Village direction.

- All plant species shall be selected from the Beverly Hills Native Plant List.
- All plants shall be alive, healthy, disease-free, and sourced from a reputable local nursery.
- Plants shall be watered thoroughly at installation.

Stone Mulch

- Apply 2 inches of medium (1.5 – 2.5 inch) river stone to all planting beds.
- Stone shall be clean, rounded, and uniform in size.
- Ensure stone does not mix into DG pathway or turf areas.

3.7 Turf Restoration

Restore all disturbed turf areas.

- Place topsoil to a minimum depth of 3 inches.
- Seed with approved turfgrass mix suited to local conditions.
- Apply straw mulch uniformly for erosion control and moisture retention.
- Maintain restored turf until establishment.

4. PERMITS & ENVIRONMENTAL COMPLIANCE

- Contractor shall obtain all required permits.
- Install and maintain soil erosion control measures.
- Protect stormwater quality and prevent runoff into the Rouge River.
- Special care shall be taken to prevent sediment, stone, or construction debris from entering the river or shoreline areas during all phases of construction.

5. SAFETY REQUIREMENTS

- Comply with MIOSHA standards.
- Establish safe boundaries around work zones.
- Provide barricades, fencing, or signage where required.

6. SUBMITTALS

- Product data for DG, solar bollards, benches, receptacles, river stone, and plant materials.
- Concrete mix design.
- Shop drawings for any custom or structural elements.

- Layout plan for pathway, lighting, pads, boulders, and plantings.

7. WARRANTY & MAINTENANCE BOND

7.1 General Warranty - The Contractor shall warrant all workmanship and materials furnished under this Contract for a period of **one (1) year** from the date of final acceptance by the Village, unless a longer warranty period is specified elsewhere in the Contract Documents. For purposes of this Section, “final acceptance” shall mean the written acceptance of the work by the Village following completion and satisfactory inspection.

During the warranty period, the Contractor shall, at no additional cost to the Village, promptly correct any defects in workmanship or materials and repair or replace any work found to be defective.

7.2 Limited Plant Warranty - The Contractor shall warrant all plant materials, including native plants and grasses, for a period of **twelve (12) months** from the date of final acceptance by the Village.

This plant warranty shall be limited to failures attributable to defective plant materials or improper installation, including but not limited to:

- Defective or non-viable nursery stock;
- Improper planting depth, orientation, or spacing;
- Root damage, girdling, or improper root preparation;
- Failure to properly backfill, tamp, or stabilize plant materials;
- Installation practices inconsistent with the Contract Documents.

Any plant materials that fail during the warranty period due to defective materials or improper installation, as determined by the Village in its reasonable discretion, shall be replaced by the Contractor at no additional cost to the Village.

Replacement plant materials shall be of the same species, size, and quality as originally specified unless otherwise approved in writing by the Village.

The warranty on replacement plant materials shall extend for the remainder of the original twelve (12)-month warranty period or for **ninety (90) days** following replacement, whichever is longer.

7.3 Maintenance Responsibilities - Routine maintenance of plant materials following final acceptance, including but not limited to watering, weeding, mulching, seasonal cutback, and general landscape care, shall be the responsibility of the Village. The Contractor shall not be responsible for plant failures attributable to post-installation

maintenance practices performed by the Village.

7.4 Maintenance Bond for Planting Scope - The Contractor shall furnish a Maintenance Bond in the amount of **twenty percent (20%) of the total contract value attributable to plant materials and planting installation** (the “Planting Scope”).

The Maintenance Bond shall be in a form acceptable to the Village and issued by a surety company licensed to do business in the State of Michigan and rated A- or better by A.M. Best.

The Maintenance Bond shall guarantee the Contractor’s obligations related to the Planting Scope, including:

- Replacement of plant materials that fail due to defective materials or improper installation;
- Correction of installation deficiencies identified during the warranty period.

The Maintenance Bond shall remain in full force and effect for the duration of the twelve (12)-month plant warranty period.

For the purposes of calculating the Maintenance Bond, the “Planting Scope” shall include the unit price for Native Perennial Plantings and the lump sum price for River Stone Mulch, inclusive of all labor, materials, and installation associated with planting beds.

7.5 Bond Claims and Remedies - If the Contractor fails to replace defective or failed plant materials or correct installation deficiencies within **thirty (30) calendar days** of written notice from the Village, the Village may make a claim against the Maintenance Bond. Bond proceeds may be used by the Village to perform or contract for the completion of required replacement or corrective work. The Village may make partial claims against the Maintenance Bond proportional to the cost of required replacement or corrective work. The Village’s exercise of rights under the Maintenance Bond shall not limit any other remedies available under the Contract or applicable law.

7.6 Warranty Exclusions - The limited plant warranty and Maintenance Bond shall not apply to plant failures or damage caused by:

- Routine or emergency maintenance practices performed by the Village;
- Vandalism or theft;
- Damage caused by third parties;
- Acts of God, including extraordinary flooding, drought, wind, or severe weather events beyond normal seasonal conditions;

- Pest or disease conditions not attributable to defective plant materials or improper installation.

The Contractor shall notify the Village in writing within **ten (10) business days** of becoming aware of any such conditions.

7.7 Manufacturer Warranties for Furnishings and Lighting - All manufacturer warranties for site furnishings, lighting, and other non-plant materials provided under this Contract shall be furnished to the Village prior to final payment. Such warranties shall be issued in the name of the Village and shall be in addition to, and not in lieu of, the Contractor's general warranty obligations.

8. INSURANCE

The Contractor shall procure and maintain the following insurance coverages:

- A. Worker's Compensation Insurance including Employers' Liability Coverage, in accordance with all applicable statutes of the State of Michigan.
- B. Commercial General Liability Insurance on an "Occurrence Basis" with limits of liability not less than \$1,000,000 per occurrence and aggregate. Coverage shall include the following extensions: (A) Contractual Liability; (B) Products and Completed Operations; (C) Independent Contractors Coverage; (D) Broad Form General Liability Extensions or equivalent, if not already included. Per job aggregate must be endorsed onto the Policy.
- C. Automobile Liability including Michigan No-Fault Coverages, with limits of liability not less than \$1,000,000 per occurrence, combined single limit for Bodily Injury, and Property Damage. Coverage shall include all owned vehicles, all non-owned vehicles, and all hired vehicles.

Proof of Insurance Coverage: The Contractor shall provide Village, at the time that the contracts are returned by him/her for execution, a Certificate of Insurance as well as the required endorsements. In lieu of required endorsements, if applicable, a copy of the policy sections where coverage is provided for additional insured and cancellation notice would be acceptable. Copies or certified copies of all policies mentioned above shall be furnished, if requested.

If any of the above coverages expire during the term of this contract, the Contractor shall deliver renewal certificates and endorsements to the Village at least ten (10) days prior to the expiration date.

9. INDEMNIFICATION CLAUSE

The Contractor awarded the bid agrees to indemnify and hold Village harmless from any and all liability arising out of this contract.

10. ESTIMATED QUANTITIES

All quantities are estimated and the Village reserves the right to adjust quantities of unit price items based on field conditions, with payment adjusted accordingly at the bid unit prices.

11. RESERVATION OF RIGHTS

- A. The Village reserves the right in its sole and absolute discretion to accept or reject any or all proposals, or alternative proposals, in whole or in part, with or without cause.
- B. The Village reserves the right to waive, or not waive, informalities or irregularities in any proposal if determined by the Village to be in its best interest.
- C. The Village reserves the right to request additional information from any or all offerors.
- D. The Village reserves the right to reject any proposal that it determines to be unresponsive and deficient in any of the information requested within RFP.
- E. The Village reserves the right to determine whether the scope of the project will be entirely as described in the RFP, a portion of the scope, or a revised scope be implemented.
- F. The Village reserves the right to select one or more consultants to perform services.
- G. The Village reserves the right to retain all proposals submitted and to use any ideas in a proposal regardless of whether that proposal is selected. Submission of a proposal indicates acceptance by the firm of the conditions contained in this RFP, unless clearly and specifically noted in the proposal submitted.
- H. The Village reserves the right to disqualify proposals that fail to respond to any requirements outlined in the RFP, or failure to enclose copies of the required documents outlined within the RFP.

**RIVERSIDE PARK IMPROVEMENT PROJECT – BID FORM
VILLAGE OF BEVERLY HILLS**

Bidder Name: _____

Company: _____

Address: _____

Phone: _____

Email: _____

Lump Sum / Unit Price Table

Item	Quantity	Unit	Unit Price	Total Price
Earthwork & Grading	LS	LS	\$_____	\$_____
DG Pathway (Complete Section)	550	LF	\$_____	\$_____
Concrete Pads (4'x10'x6")	4	EA	\$_____	\$_____
Benches	4	EA	\$_____	\$_____
Trash Receptacles	4	EA	\$_____	\$_____
Solar Light Bollards	19	EA	\$_____	\$_____
Boulder Installation	9	EA	\$_____	\$_____
Native Perennial Plantings	300	EA	\$_____	\$_____
River Stone Mulch	LS	LS	\$_____	\$_____
Turf Restoration	LS	LS	\$_____	\$_____

Mobilization & LS LS \$ _____ \$ _____
Cleanup

TOTAL BID PRICE: \$ _____

Bidder Signature: _____

Date: _____

BIDDER'S REFERENCE PAGE

(Submit with Bid)

The Contractor shall submit verifiable references for municipal work and be familiar with all aspects of safe tree removal operations. Each reference shall be for work actually performed by the Bidder (sub-contractor references are not applicable).

ALL REFERENCES WILL BE TREATED AS THE CONTRACTOR'S CONFIDENTIAL BUSINESS INFORMATION. **Previous work for the Owner may be used as a reference. Complete each item for all 3 references.**

Owner/Agency:	
Address:	
City, State, Zip	
Contact:	
Phone:	

Owner/Agency:	
Address:	
City, State, Zip	
Contact:	
Phone:	

Owner/Agency:	
Address:	
City, State, Zip	
Contact:	
Phone:	

Only contractors experienced in this type of work will be considered. Failure to provide sufficient verifiable references will result in rejection of this bid.

**VILLAGE OF BEVERLY HILLS
SUBMISSION FORM**

IT IS UNDERSTOOD THAT THE VILLAGE OF BEVERLY HILLS IS A GOVERNMENTAL UNIT AND AS SUCH IS EXEMPT FROM THE PAYMENT OF ALL STATE AND FEDERAL TAXES APPLYING ON THE ABOVE-MENTIONED WORK, THEREFORE, THE ABOVE PRICES DO NOT INCLUDE THIS AMOUNT.

All bids must be submitted on the Village's bid sheet.

Submission of a bid will be construed as a conclusive presumption that the bidder is thoroughly familiar with the bid sheet and specifications, and that he understands and agrees to abide by each, and all of the stipulations and requirements contained therein.

BIDDERS ARE REQUESTED TO SUBMIT ALL AVAILABLE DATA AND DESCRIPTIVE LITERATURE COVERING THE PROPOSED SERVICES TO BE FURNISHED.

THE UNDERSIGNED, by execution of this bid, certified that he is the _____ of the firm named as bidder in the bid; and that he signs the bid on behalf of the firm; and that he is authorized to execute the same in behalf of said firm.

NAME AND ADDRESS OF BIDDER:

COMPANY NAME

ADDRESS

CITY _____ STATE _____ ZIP _____

SUBMITTED BY

(NAME)

(TITLE)

SIGNATURE _____

TELEPHONE _____ FAX _____

DATE _____

THIS PAGE MUST BE RETURNED WITH BID SHEET

VILLAGE OF BEVERLY HILLS**Native Plant List****PERENNIAL WILDFLOWERS**

Scientific Name	Common Name	Height (ft)
<i>Achillea millefolium</i>	Yarrow	1-3
<i>Actaea pachypoda</i>	White Baneberry	1-2
<i>Anemone canadensis</i>	Canada Anemone	1-2
<i>Aquilegia canadensis</i>	Wild Columbine	1-3
<i>Aralia racemosa</i>	Spikenard	3-6
<i>Asclepias incarnata</i>	Swamp Milkweed	3-4
<i>Asclepias tuberosa</i>	Butterflyweed	1-3
<i>Campanula rotundifolia</i>	Harebell	1-2
<i>Coreopsis lanceolata</i>	Sand Coreopsis	1-2
<i>Desmodium canadense</i>	Showy Tick-trefoil	3-4
<i>Doellingeria umbellata</i>	Flat-top White Aster	2-4
<i>Eupatoriadelphus maculatus</i>	Spotted Joe-pye Weed	4-5
<i>Geranium maculatum</i>	Wild Geranium	1-2
<i>Heliopsis helianthoides</i>	False Sunflower	4-6
<i>Iris versicolor</i>	Wild Blue Flag	2-3
<i>Liatris aspera</i>	Rough Blazing Star	3-4
<i>Lobelia cardinalis</i>	Cardinal Flower	2-4
<i>Monarda fistulosa</i>	Wild Bergamot	2-4
<i>Penstemon digitalis</i>	Foxglove Beardtongue	3-4
<i>Penstemon hirsutus</i>	Hairy Beardtounge	1-2
<i>Potentilla simplex</i>	Common Cinquefoil	1-2
<i>Pycnanthemum virginianum</i>	Mountain Mint	1-2
<i>Rudbeckia hirta</i>	Black-eyed Susan	1-3
<i>Solidago caesia</i>	Blue-stemmed Goldenrod	2-3
<i>Symphyotrichum oolentangiense</i>	Skyblue Aster	2-3
<i>Symphyotrichum puniceum</i>	Swamp Aster	3-5
<i>Thalictrum dasycarpum</i>	Purple Meadow-rue	3-7
<i>Thalictrum dioicum</i>	Early Meadow-rue	2-3
<i>Tradescantia ohiensis</i>	Common Spiderwort	2-3
<i>Verbena hastata</i>	Blue Vervain	3-5
<i>Verbena stricta</i>	Hoary Vervain	2-4

ORNAMENTAL GRASSES

Scientific Name	Common Name	Height (ft)
Andropogon gerardii	Big Bluestem	5-7
Carex pensylvanica	Pennsylvania Sedge	.5-1
Carex stricta	Tussock Sedge	2-4
Eragrostis spectabilis	Purple Love Grass	1-2
Juncus effusus	Soft-stemmed Rush	1-3
Panicum virgatum	Switch Grass	3-5
Schizachyrium scoparium	Little Bluestem	2-4
Sorghastrum nutans	Indian Grass	4-6

Solar Bollard Lights

5' Crushed Stone Path

5'x10' Concrete Pad
with Bench and Trash
Can

3'-4' Boulders

Waterside Dr

Rouge River

Kayak Launch

Perennial Beds

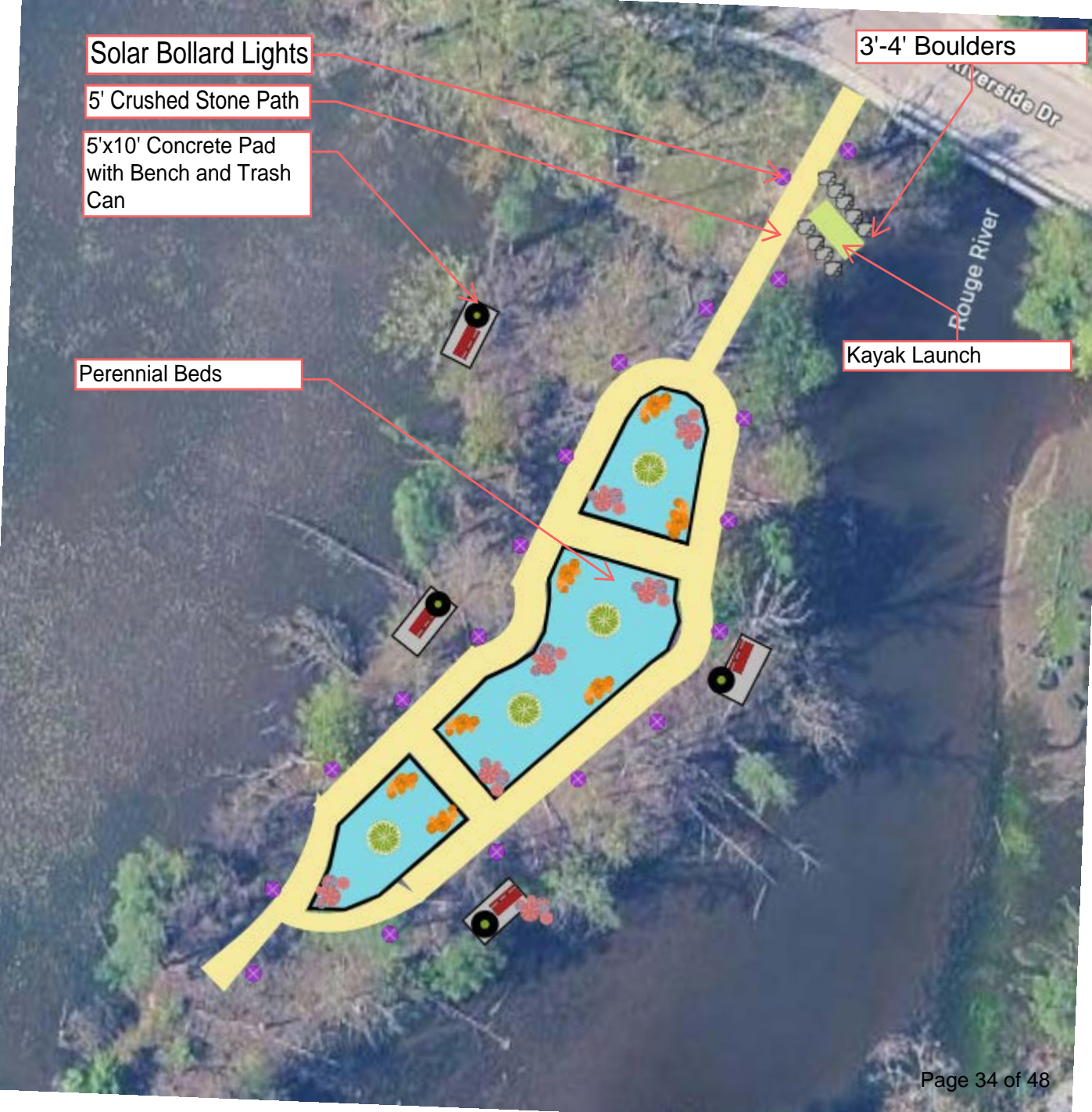

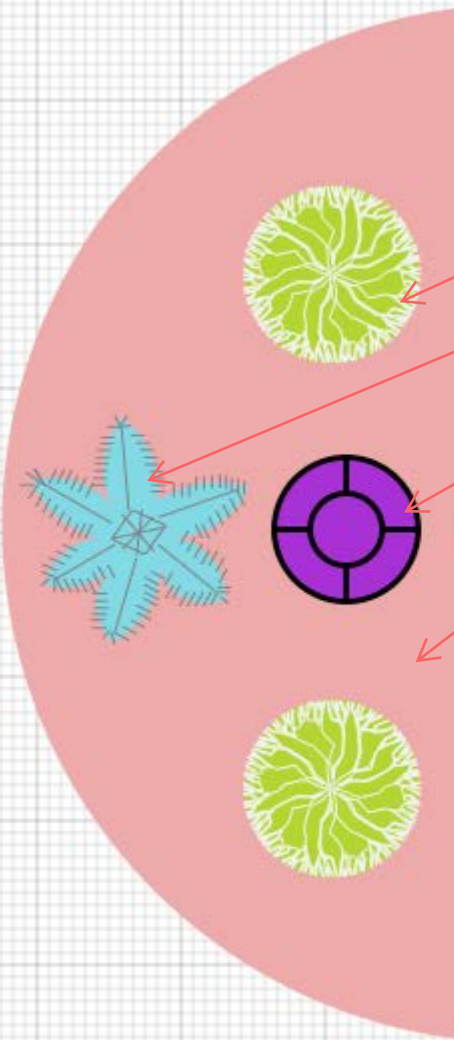

5' Pathway

Ornamental Grass

Perennial Planting

Solar Bollard Light

Riverstone Bed

SOLAR LED BOLLARD LIGHTS

SEARCH CODE: SC43776



FEATURES:

- Color Temperatures: 4000K
- Finish: Available in bronze or black finish
- Rated hours: 50,000 hrs
- Beam Angle : 120°
- Lumens: 390LM Max.
- Flat Top with Cone Reflector & Frosted Lens
- Corrosion Resistant Aluminum for Exterior
- Mounting Accessories & Anchor Bolts Included (7-1/2" long)

PHOTOMETRICS:

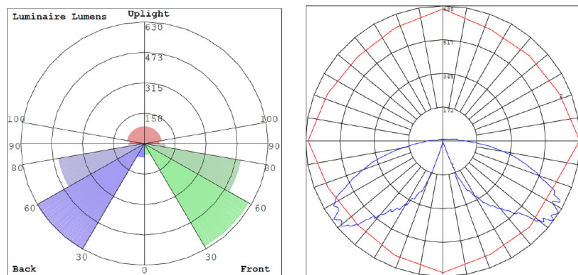

BUD Rating: B1-U3-G2

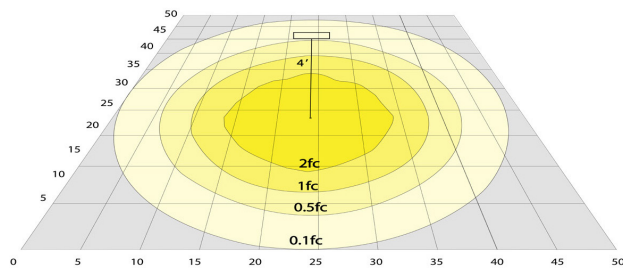

Area 75' x 65' Mounting Height: 4'

WARRANTY & LISTINGS:

- 5-year warranty
- UL / cUL Certified
- IP65 Waterproof

ELECTRICAL:

- Power Factor: >0.9
- Efficacy: 130 LPW
- Operating Temperature: 0°F to 113°F
- Color Rendering Index: CRI ≥ 70

APPLICATION:

- Bollards are designed for walkways, entrance ways, drives and other small-area lighting applications where low mounting heights are desirable

DIMENSIONS:

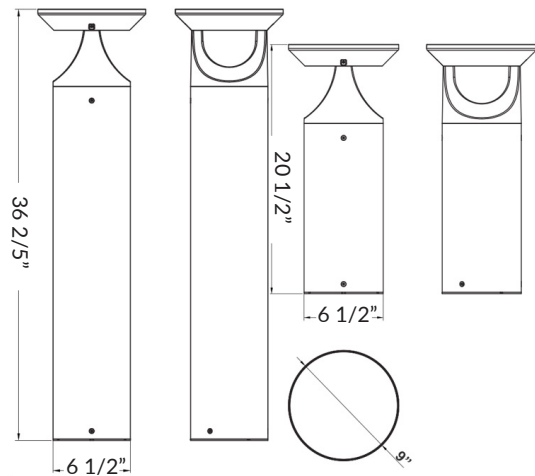

36 2/5" (H) x 6 1/2" (W) x 9" (D)
20 1/2" (H) x 6 1/2" (W) x 9" (D)

SPECIFICATIONS:

Product Code	Height	Wattage	Lumens	Finish	Color Temperature
SOL-BL-301-14-40K-BR	14 INCH	3W	390 LM	Bronze	4000K
SOL-BL-301-14-40K-BK	14 INCH	3W	390 LM	Black	4000K
SOL-BL-301-30-40K-BK	30 INCH	3W	390 LM	Black	4000K
SOL-BL-301-30-40K-BR	30 INCH	3W	390 LM	Bronze	4000K

SOLAR LED BOLLARD LIGHTS

SEARCH CODE: SC43776



ELECTRICAL INFORMATION:

Solar Panel Wattage	5W							
Charging Time	8>Hours							
Operating Time	Normal Mode> 11 Hours, Intelligent Mode 2-3 Days							
Working Mode	Lighting Scheme	Time 1	Time 2	Time 3	Time4	Time 5	Energy Consumption	Working Hours In Rainy Day
	1 (Factory Default)	6H x 30%	0H x 100%	0H x 100%	TOT x 0%	1H x 30%	7.4Wh	4-5 Days
	2	6H x 30%	6H x 30%	0H x 100%	0H x 0%	0H x 100%	12.6Wh	3-4 Days
	3	6H x 50%	6H x 30%	0H x 100%	0H x 0%	0H x 100%	16.8Wh	2-3 Days
	4	4H x 70%	4H x 30%	4H x 30%	0H x 0%	0H x 100%	18.2Wh	1-2 Days
	5	4H x 100%	2H x 50%	0H x 100%	0H x 0%	0H x 100%	17.5Wh	2-3 Days
	6	2H x 50%	4H x 30%	0H x 100%	TOT x 20%	1H x 30%	12.3Wh	3-4 Days
	7	4H x 80%	2H x 30%	0H x 100%	TOT x 0%	1H x 80%	16.1Wh	2-3 Days

REMOTE CONTROL INSTRUCTIONS:

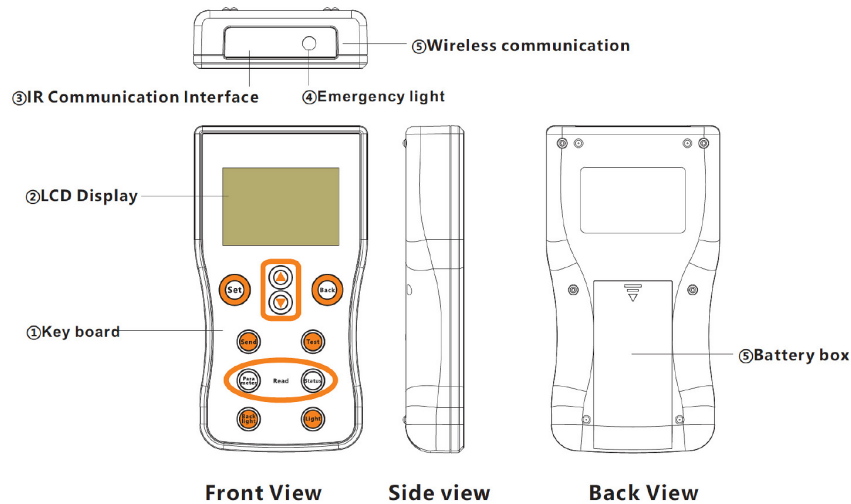

Key Name	Function	Long press key function
Set	Parameter setting/ confirmation	Press "Set" and "Light" key to lock or unlock the parameters
▲	1. Menu Page Up 2. Increase the setting data	Continuous increase the setting data
▼	1. Menu Page Down 2. Decrease the setting data	Continuous decrease the setting data
Back	Return to the menu / exit	Press "Set" and "Back" key to enter the communication selection interface
Send	Send Parameters	_____
Test	Test the setting	_____
Read	Parameter	Read Parameters
	Status	Read running status
Backlight	Turn on the LCD backlight	Press "Backlight" and "Back" key to enter or exit the transport mode
Light	1. Open the emergency lighting 2. SOS lights switch	Press "Light" and "Set" key to lock or unlock the parameters

Lakeside is a lighthearted line of benches and litters designed by architect Margaret McCurry, a master of American vernacular design. The forms and motifs of this popular favorite are inspired by familiar themes in nature, architecture and historic design. Two bench options share a common bent steel frame that recalls the traditional front-porch platform swing, while seating surfaces have distinctly different characters. The first features sheet steel enlivened with plasma-cut patterns of graceful grasses or falling leaves. The second has a slatted seat and back of “pickets” that make whimsical reference to the American domestic landscape. Steel shells and motifs from nature are echoed in Lakeside litters, and custom patterns can be created for signature applications.

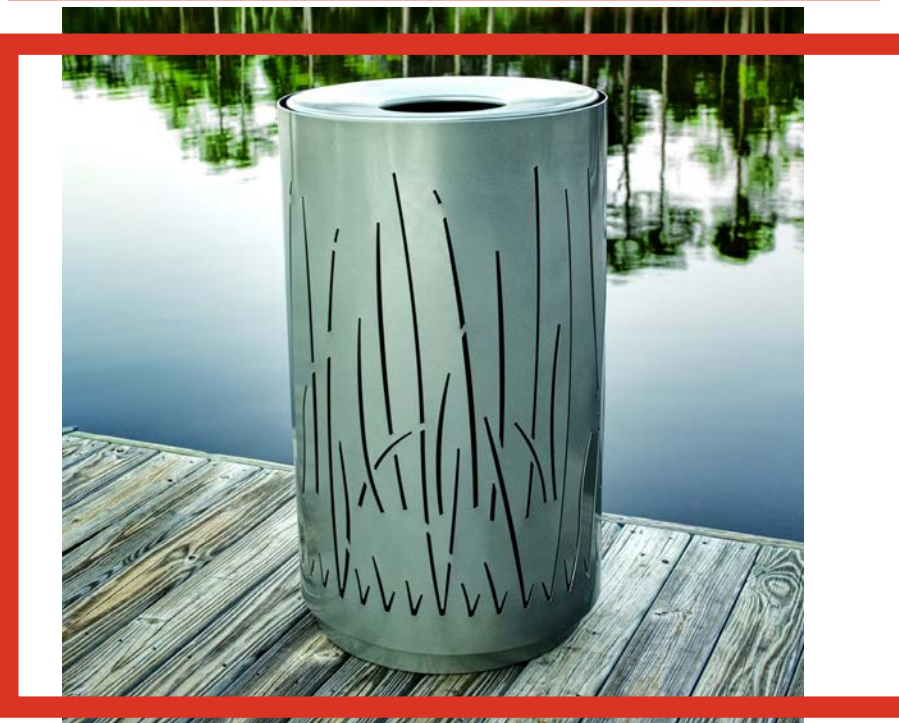

Lakeside litter receptacles are simple steel cylinders with a recessed base, plain or with plasma-cut patterns that beautifully integrate with other Lakeside elements and the landscape. Litters are 36” tall and 21” in diameter and have removable polyethylene liners. The side-opening version holds 30-gallons, the top-opening version holds 35. Lakeside litters, like all steel Lakeside elements, are finished with Landscape Forms’ proprietary Pangard II® polyester powdercoat in the full Landscape Forms color palette.



Lakeside

landscapeforms

Product Data Sheet



Designer Margaret McCurry started with steel side frames that recall platform swings. Her inspiration for the seating was a picket fence around a Victorian era cottage and reflections of forms in the outdoor environments. In the Lakeside bench, as in her architecture, the linkage is artfully transformed so, as she puts it, "the history and memory are there, but they're jogged a bit."

Benches

- Benches are made with dual 1/4" thick steel frames, welded and bolted together with stainless steel hardware.
- Benches are 67" in length and available backed or backless.
- End arms standard on backed benches.
- Picket fence panels may be specified in Polysite™ or wood.
- All picket fence boards are attached to the steel bench frame with stainless steel hardware.
- Metal seats and seat backs are available in grass, leaf or custom designs which are plasma-cut steel panels, bolted to the bench frame with stainless steel hardware.
- Bench comes standard with freestanding/surface mount support.
- Metal panels may be designed with a custom pattern for minimal up charge. Ask your Landscape Forms representative for details.

Litter Receptacles

- Lakeside litter receptacles are available in side or top-opening designs.
- Side-opening litter receptacle has a 30-gallon capacity, top-opening has a 35-gallon capacity.
- Steel panels are available in grass, leaf, custom or plain designs which are plasma-cut steel.
- Litters come standard with a removable black polyethylene liner.
- Receptacles are standard with freestanding/surface mount base.

Bench	Style	Depth	Width	Height	Weight
	Grass Backless	19"	67"	18"	138 lbs
	Grass Backed	25"	67"	35"	197 lbs
	Leaf Backed	25"	67"	35"	197 lbs
	Picket Fence Backless	19"	67"	18"	Poly 125 lbs Wood 108 lbs
	Picket Fence Backed	25"	67"	35"	Poly 195 lbs Wood 158 lbs

Litter	Style	Diameter	Height	Weight
	Grass Side-Opening	21"	36"	101 lbs
	GRASS Leaf Top-Opening	21"	36"	106 lbs
	Plain Top-Opening	21"	36"	106 lbs

Lakeside Bench

Material / Colors Sheet

Vivid Series - Powdercoated Metal* (Fine Texture)



Neutral Series - Powdercoated Metal*

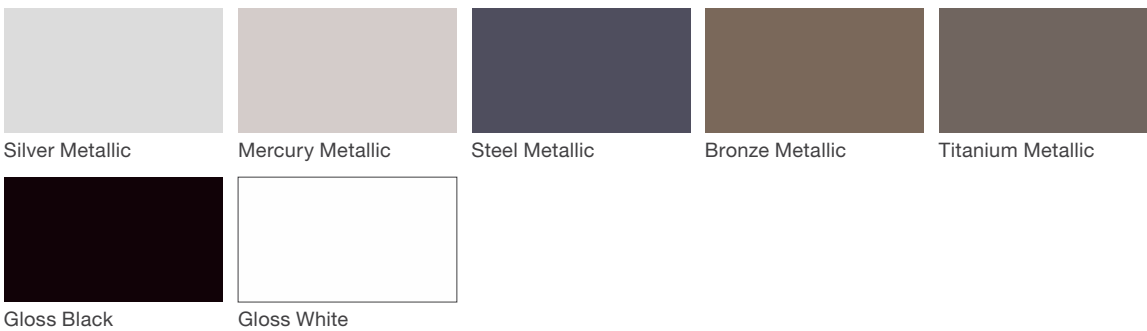

Architectural Series - Powdercoated Metal* (Fine Texture)

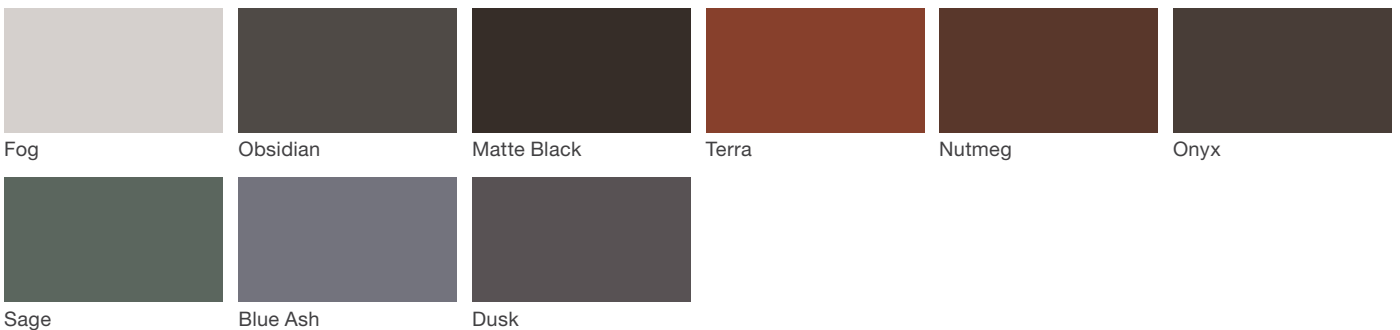



Bid Tabulation Form

Village of Beverly Hills

March 11, 2026

Riverside Park Landscape Improvement Project

FIRM NAME (BIDDER)	TOTAL BID AMOUNT
BRADLEY HOLMES	\$133,537.50
CONTINUUM SERVICES	\$188,076.00
D & E LANDSCAPING & GRADING INC	\$182,960.02
DALCO SERVICES LLC	\$149,580.00
JASON'S OUTDOOR SERVICES	\$121,468.50
JOHNSON LANDSCAPING	\$219,000.00
MILLER LANDSCAPE	\$178,247.15
ROLAR CONSTRUCTION CORP	\$119,784.00
SHERMAN NURSEY FARMS	\$161,144.00
SPURLOCKS	\$149,182.80



**RIVERSIDE PARK IMPROVEMENT PROJECT – BID FORM
VILLAGE OF BEVERLY HILLS**

Bidder Name: Brooks Bauer
Company: Rolar Construction Corp
Address: 5860 Frazho Rd Warren, MI 48091
Phone: 586-557-7941
Email: bbauer@rolarinc.com

Lump Sum / Unit Price Table

Item	Quantity	Unit	Unit Price	Total Price
Earthwork & Grading	LS	LS	\$ <u>21,222.00</u>	\$ <u>21,222.00</u>
DG Pathway (Complete Section)	550	LF	\$ <u>30.00</u>	\$ <u>16,500.00</u>
Concrete Pads (4'x10'x6")	4	EA	\$ <u>1,025.00</u>	\$ <u>4,100.00</u>
Benches	4	EA	\$ <u>4,234.00</u>	\$ <u>16,936.00</u>
Trash Receptacles	4	EA	\$ <u>2,548.00</u>	\$ <u>10,192.00</u>
Solar Light Bollards	19	EA	\$ <u>886.00</u>	\$ <u>16,834.00</u>
Boulder Installation	9	EA	\$ <u>680.00</u>	\$ <u>6,120.00</u>
Native Perennial Plantings	300	EA	\$ <u>32.00</u>	\$ <u>9,600.00</u>
River Stone Mulch	LS	LS	\$ <u>12,200.00</u>	\$ <u>12,200.00</u>
Turf Restoration	LS	LS	\$ <u>3,230.00</u>	\$ <u>3,230.00</u>

Mobilization & LS LS \$ 2,850.00 \$ 2,850.00
Cleanup

TOTAL BID PRICE: \$ 119,784.00

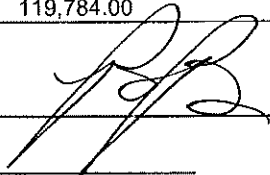
Bidder Signature:  _____

Date: 3 / 10 / 26

BIDDER'S REFERENCE PAGE

(Submit with Bid)

The Contractor shall submit verifiable references for municipal work and be familiar with all aspects of safe tree removal operations. Each reference shall be for work actually performed by the Bidder (sub-contractor references are not applicable).

ALL REFERENCES WILL BE TREATED AS THE CONTRACTOR'S CONFIDENTIAL BUSINESS INFORMATION. Previous work for the Owner may be used as a reference. Complete each item for all 3 references.

Owner/Agency:	City of Royal Oak
Address:	203 S. Troy
City, State, Zip	Royal Oak , MI
Contact:	Joseph Murphy
Phone:	248-246-3285

Owner/Agency:	Hennessey Engineers
Address:	13500 Reeck Rd
City, State, Zip	Southgate, MI 48195
Contact:	John Miller
Phone:	734-759-1600

Owner/Agency:	City of Roseville
Address:	18185 Sycamore
City, State, Zip	Roseville, MI 48066
Contact:	Tony Lapinski
Phone:	586-634-0228

Only contractors experienced in this type of work will be considered. Failure to provide sufficient verifiable references will result in rejection of this bid.

**VILLAGE OF BEVERLY HILLS
SUBMISSION FORM**

IT IS UNDERSTOOD THAT THE VILLAGE OF BEVERLY HILLS IS A GOVERNMENTAL UNIT AND AS SUCH IS EXEMPT FROM THE PAYMENT OF ALL STATE AND FEDERAL TAXES APPLYING ON THE ABOVE-MENTIONED WORK, THEREFORE, THE ABOVE PRICES DO NOT INCLUDE THIS AMOUNT.

All bids must be submitted on the Village's bid sheet.

Submission of a bid will be construed as a conclusive presumption that the bidder is thoroughly familiar with the bid sheet and specifications, and that he understands and agrees to abide by each, and all of the stipulations and requirements contained therein.

BIDDERS ARE REQUESTED TO SUBMIT ALL AVAILABLE DATA AND DESCRIPTIVE LITERATURE COVERING THE PROPOSED SERVICES TO BE FURNISHED.

THE UNDERSIGNED, by execution of this bid, certified that he is the PM / Officer of the firm named as bidder in the bid; and that he signs the bid on behalf of the firm; and that he is authorized to execute the same in behalf of said firm.

NAME AND ADDRESS OF BIDDER:

COMPANY NAME

Rolar Construction Corp

ADDRESS

5860 Frazho Rd

CITY Warren STATE MI ZIP 48047

SUBMITTED BY

Brooks Bauer

Project Manager

(NAME)

(TITLE)

SIGNATURE



TELEPHONE 586-557-7941

FAX _____

DATE 3 / 9 / 26

THIS PAGE MUST BE RETURNED WITH BID SHEET

AIA[®] Document A310[™] – 2010

Bid Bond

CONTRACTOR:
(Name, legal status and address)
Rolar Property Services Inc.
5860 Frazho
Warren, MI 48091

OWNER:
(Name, legal status and address)
Village of Beverly Hills
18500 West Thirteen Mile Road
Beverly Hills, MI 48025

BOND AMOUNT: Five Percent (5%) of Amount Bid

PROJECT:
(Name, location or address, and Project number, if any)
Riverside Park Landscape Improvement Project

SURETY:
(Name, legal status and principal place of business)

Swiss Re Corporate Solutions America Insurance Corporation
1200 Main St, Suite 800
Kansas City, MO 64105-2478

This document has important legal consequences. Consultation with an attorney is encouraged with respect to its completion or modification.

Any singular reference to Contractor, Surety, Owner or other party shall be considered plural where applicable.

The Contractor and Surety are bound to the Owner in the amount set forth above, for the payment of which the Contractor and Surety bind themselves, their heirs, executors, administrators, successors and assigns, jointly and severally, as provided herein. The conditions of this Bond are such that if the Owner accepts the bid of the Contractor within the time specified in the bid documents, or within such time period as may be agreed to by the Owner and Contractor, and the Contractor either (1) enters into a contract with the Owner in accordance with the terms of such bid, and gives such bond or bonds as may be specified in the bidding or Contract Documents, with a surety admitted in the jurisdiction of the Project and otherwise acceptable to the Owner, for the faithful performance of such Contract and for the prompt payment of labor and material furnished in the prosecution thereof; or (2) pays to the Owner the difference, not to exceed the amount of this Bond, between the amount specified in said bid and such larger amount for which the Owner may in good faith contract with another party to perform the work covered by said bid, then this obligation shall be null and void, otherwise to remain in full force and effect. The Surety hereby waives any notice of an agreement between the Owner and Contractor to extend the time in which the Owner may accept the bid. Waiver of notice by the Surety shall not apply to any extension exceeding sixty (60) days in the aggregate beyond the time for acceptance of bids specified in the bid documents, and the Owner and Contractor shall obtain the Surety's consent for an extension beyond sixty (60) days.

If this Bond is issued in connection with a subcontractor's bid to a Contractor, the term Contractor in this Bond shall be deemed to be Subcontractor and the term Owner shall be deemed to be Contractor.

When this Bond has been furnished to comply with a statutory or other legal requirement in the location of the Project, any provision in this Bond conflicting with said statutory or legal requirement shall be deemed deleted herefrom and provisions conforming to such statutory or other legal requirement shall be deemed incorporated herein. When so furnished, the intent is that this Bond shall be construed as a statutory bond and not as a common law bond.

Signed and sealed this 11th day of March, 2026

(Witness)

(Witness)

Rolar Property Services Inc.

(Principal)

(Seal)

(Title) David Lawson President

Swiss Re Corporate Solutions America Insurance Corporation

(Surety)

(Seal)

(Title)

Krista L Pocket, Attorney-in-Fact

Init. AIA Document A310[™] – 2010. Copyright © 1963, 1970 and 2010 by The American Institute of Architects. All rights reserved. **WARNING:** This AIA[®] Document is protected by U.S. Copyright Law and International Treaties. Unauthorized reproduction or distribution of this AIA[®] Document, or any portion of it, may result in severe civil and criminal penalties, and will be prosecuted to the maximum extent possible under the law. This document was created on 01/27/2012 07:23:12 under the terms of AIA Documents-on-Demand[™] order no. 2008397483, and is not for resale. This document is licensed by The American Institute of Architects for one-time use only, and may not be reproduced prior to its completion. 051110

SWISS RE CORPORATE SOLUTIONS

SWISS RE CORPORATE SOLUTIONS AMERICA INSURANCE CORPORATION ("SRCSAIC")
SWISS RE CORPORATE SOLUTIONS PREMIER INSURANCE CORPORATION ("SRCSPIC")
WESTPORT INSURANCE CORPORATION ("WIC")

GENERAL POWER OF ATTORNEY

KNOW ALL MEN BY THESE PRESENTS, THAT SRCSAIC, a corporation duly organized and existing under laws of the State of Missouri, and having its principal office in the City of Kansas City, Missouri, and SRCSPIC, a corporation organized and existing under the laws of the State of Missouri and having its principal office in the City of Kansas City, Missouri, and WIC, organized under the laws of the State of Missouri, and having its principal office in the City of Kansas City, Missouri, each does hereby make, constitute and appoint:

ROBERT TROHEC, IAN J. DONALD, JEFFREY A. CHANDLER, ALAN P. CHANDLER, SUSAN L. SMALL, T. J. GRIFFIN, JOHN L. BUDDÉ,
TERRENCE J. GRIFFIN, TERRI L. YOUNG, PATRIC K.E. WILKINS, WENDY LEE HINSON, BRYAN FORMSA, and KRISTA L. POCKET

JOINTLY OR SEVERALLY

Its true and lawful Attorney(s)-in-Fact, to make, execute, seal and deliver, for and on its behalf and as its act and deed, bonds or other writings obligatory in the nature of a bond on behalf of each of said Companies, as surety, on contracts of suretyship as are or may be required or permitted by law, regulation, contract or otherwise, provided that no bond or undertaking or contract or suretyship executed under this authority shall exceed the amount of:

TWO HUNDRED MILLION (\$200,000,000.00) DOLLARS

This Power of Attorney is granted and is signed by facsimile under and by the authority of the following Resolutions adopted by the Boards of Directors of both SRCSAIC and SRCSPIC at meetings duly called and held on the 18th of November 2021 and WIC by written consent of its Executive Committee dated July 18, 2011.

"RESOLVED, that any two of the President, any Managing Director, any Senior Vice President, any Vice President, the Secretary or any Assistant Secretary be, and each or any of them hereby is, authorized to execute a Power of Attorney qualifying the attorney named in the given Power of Attorney to execute on behalf of the Corporation bonds, undertakings and all contracts of surety, and that each or any of them hereby is authorized to attest to the execution of any such Power of Attorney and to attach therein the seal of the Corporation; and it is

FURTHER RESOLVED, that the signature of such officers and the seal of the Corporation may be affixed to any such Power of Attorney or to any certificate relating thereto by facsimile, and any such Power of Attorney or certificate bearing such facsimile signatures or facsimile seal shall be binding upon the Corporation when so affixed and in the future with regard to any bond, undertaking or contract of surety to which it is attached."

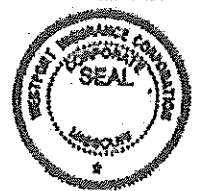

By: Erik Janssens
Senior Vice President of SRCSAIC & Senior Vice President of SRCSPIC & Senior Vice President of WIC

By: Gerald Jantowski
General Counsel, Vice President of SRCSAIC & Vice President of SRCSPIC & Vice President of WIC

IN WITNESS WHEREOF, SRCSAIC, SRCSPIC, and WIC have caused their official seals to be hereunto affixed, and these presents to be signed by their authorized officers

this 10TH day of NOVEMBER 20 23

State of Illinois
County of Cook

Swiss Re Corporate Solutions America Insurance Corporation
Swiss Re Corporate Solutions Premier Insurance Corporation
Westport Insurance Corporation

On this 10TH day of NOVEMBER 20 23, before me, a Notary Public personally appeared Erik Janssens, Senior Vice President of SRCSAIC and Senior Vice President of SRCSPIC and Senior Vice President of WIC and Gerald Jantowski, Vice President of SRCSAIC and Vice President of SRCSPIC and Vice President of WIC, personally known to me, who being by me duly sworn, acknowledged that they signed the above Power of Attorney as officers of and acknowledged said instrument to be the voluntary act and deed of their respective companies.

Karen M. Szweda, Notary

I, Jeffrey Goldberg, the duly elected Senior Vice President and Assistant Secretary of SRCSPIC and SRCSPIC and WIC, do hereby certify that the above and foregoing is a true and correct copy of a Power of Attorney given by said SRCSAIC and SRCSPIC and WIC, which is still in full force and effect. IN WITNESS WHEREOF, I have set my hand and affixed the seals of the Companies this 11th day of March 2026

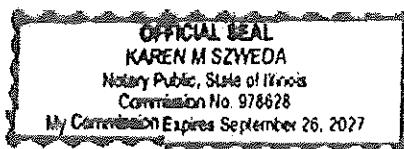

Jeffrey Goldberg, Senior Vice President & Assistant Secretary of SRCSAIC and SRCSPIC and WIC